

GENERAL NOTES

SLOPE PROTECTION SHALL BE PLACED UNDER THE ENDS OF THE BRIDGE AS SHOWN IN THE DETAILS. THE CONTRACTOR, AT HIS OPTION, MAY USE ALTERNATE "B" ONLY FOR HIGHWAY OVER HIGHWAY GRADE SEPARATIONS WITH 2:1 END BENT SLOPE IN RURAL, UNPOPULATED AREAS. STRAIGHT EDGING WILL NOT BE REQUIRED UNLESS, IN THE OPINION OF THE ENGINEER, VISUAL INSPECTION INDICATES A NEED FOR IT. MEASUREMENT AND PAYMENT SHALL BE AS PRESCRIBED IN SECTION 462 OF THE STANDARD SPECIFICATIONS. FOR BERM WIDTH, SEE GENERAL DRAWING.

ALTERNATE "A"

ALTERNATE "A" SHALL CONSIST OF 4" POURED-IN-PLACE CONCRETE PAVING AS SHOWN IN THE DETAILS ON THIS SHEET. CONCRETE SHALL BE CLASS "B". THE CONCRETE SURFACE SHALL BE FLOATED WITH A WOODEN FLOAT AND FINISHED. WELDED WIRE FABRIC REINFORCING SHALL BE 6 X 6 - W1.4 X W1.4, 60" WIDE. SLOPE PROTECTION SHALL BE POURED IN 5' STRIPS AS SHOWN IN THE "POURING DETAIL" WITH 2'-0" LONG #4 BARS PLACED ALONG THE SLOPE BETWEEN STRIPS AT 1'-6" MAXIMUM SPACING. SLOPE PROTECTION MAY BE POURED IN ALTERNATE 4' AND 5' STRIPS AS SHOWN IN THE "OPTIONAL POURING DETAIL" WITH ADJACENT RUNS OF WELDED WIRE FABRIC LAPPING AT LEAST 6". THE COST OF THE WELDED WIRE FABRIC AND #4 BARS, IF USED, SHALL BE INCLUDED IN THE CONTRACT UNIT PRICE BID PER SQUARE YARD FOR SLOPE PROTECTION.

ALTERNATE "B"

ALTERNATE "B" SHALL CONSIST OF A COMBINATION CONCRETE SLAB AND STONE SLOPE PROTECTION. THE CONCRETE PORTIONS SHALL CONSIST OF PAVED STRIPS ALONG THE DITCH AS SHOWN IN THE DETAILS. FILTER FABRIC AND 8" OF STONE SHALL BE PLACED OVER THE REMAINING AREA SHOWN ON THE PLANS TO BE COVERED WITH SLOPE PROTECTION. CONCRETE SHALL BE CLASS "B". THE COST OF THE CONCRETE, FILTER FABRIC, STONE AND WELDED WIRE FABRIC 6 X 6 - W1.4 X W1.4, SHALL BE INCLUDED IN THE CONTRACT UNIT PRICE BID PER SQUARE YARD FOR SLOPE PROTECTION. SUBGRADING, STONE TYPE, STONE SIZING AND HERBICIDE PROTECTION, SHALL BE IN ACCORDANCE WITH THE STANDARD SPECIFICATIONS EXCEPT THE HERBICIDE TYPE SHALL BE SUBMITTED TO THE ENGINEER FOR APPROVAL PRIOR TO APPLICATION.

| BRIDGE @ STA. | INCH SLOPE PROTECTION | * WELDED WIRE FABRIC 60 INCHES WIDE |
|---------------|-----------------------|-------------------------------------|
| | SQUARE YARDS | APPROX. L.F. |
| END BENT 1 | | |
| END BENT 2 | | |

* QUANTITY SHOWN IS BASED ON 5' POURS.

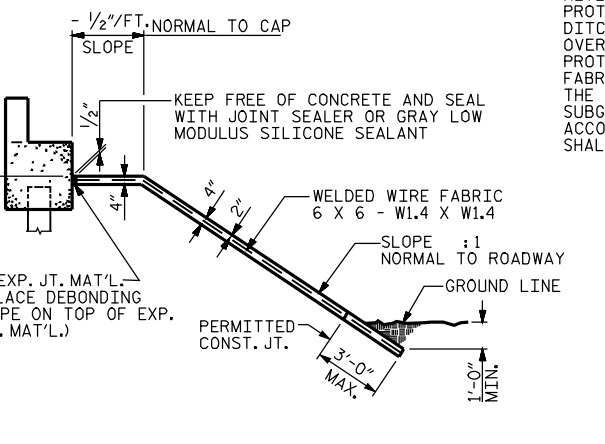
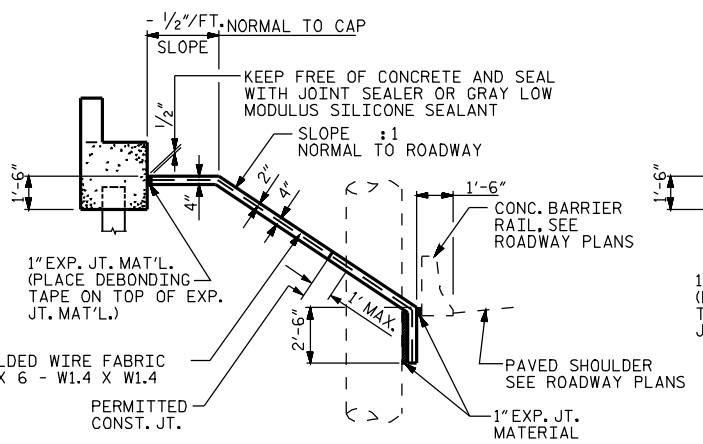
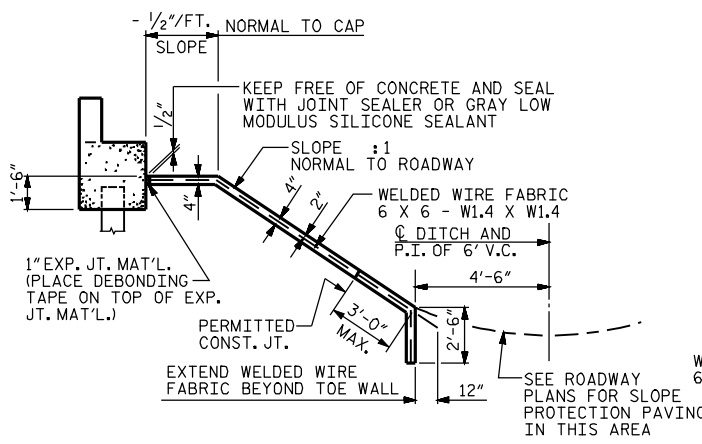

SECTION ALONG ROADWAY WHEN FILL CATCHES IN DITCH

SECTION ALONG ROADWAY WITH SHOULDER PIER

SECTION ALONG ROADWAY WHEN DITCH IS NOT PROVIDED

DETAILS FOR ALTERNATE "A"

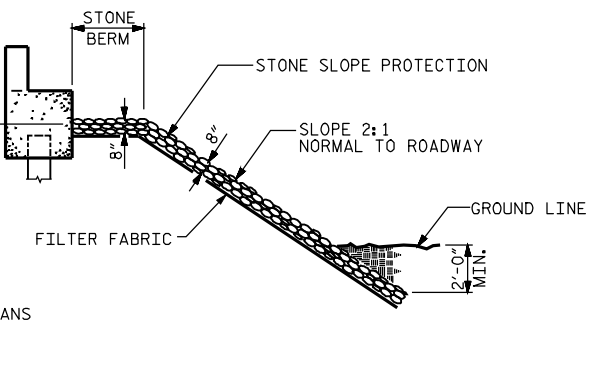
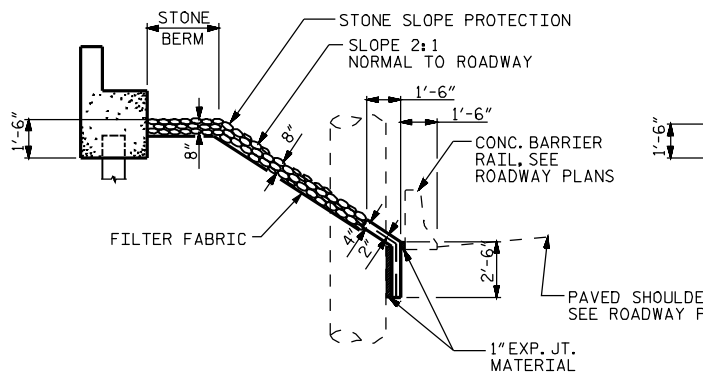
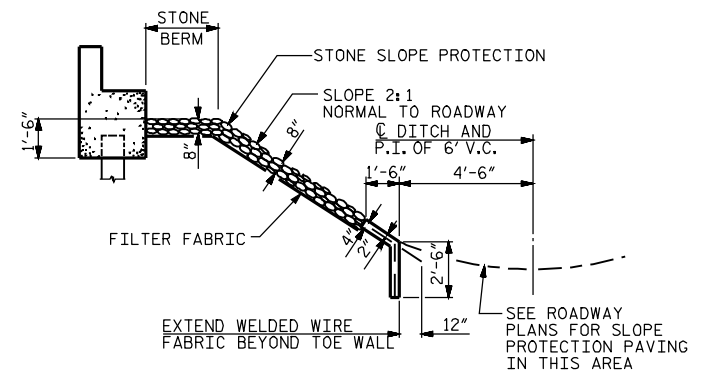

SECTION ALONG ROADWAY WHEN FILL CATCHES IN DITCH

SECTION ALONG ROADWAY WITH SHOULDER PIER

SECTION ALONG ROADWAY WHEN DITCH IS NOT PROVIDED

DETAILS FOR ALTERNATE "B"

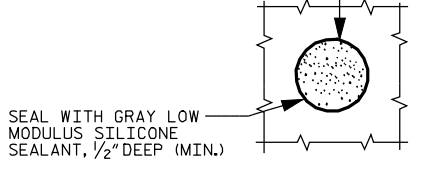

PLAN WHERE CONCRETE SLOPE PROTECTION MUST BE PLACED AROUND A BENT COLUMN

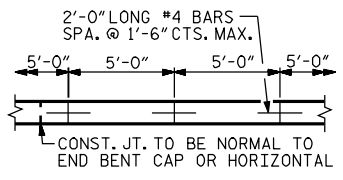

POURING DETAIL

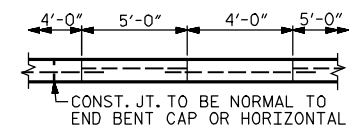

OPTIONAL POURING DETAIL

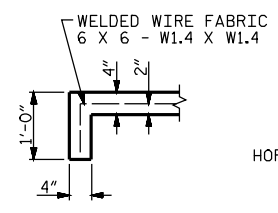

SECTION A-A

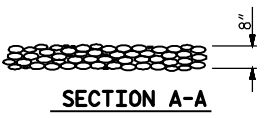

SECTION A-A

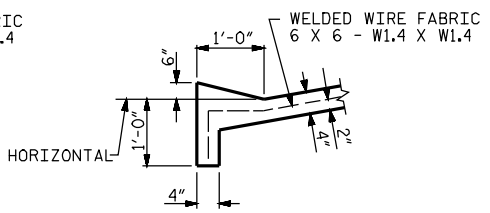

SECTION B-B



SECTION B-B

PROJECT NO. _____

_____ COUNTY

STATION: _____

SHEET 1 OF 2

STATE OF NORTH CAROLINA
DEPARTMENT OF TRANSPORTATION
RALEIGH
STANDARD
SLOPE PROTECTION
DETAILS

| REVISIONS | | | | SHEET NO. | |
|-----------|-----|-------|-----|-----------|-------|
| NO. | BY: | DATE: | NO. | BY: | DATE: |
| 1 | | | 3 | | |
| 2 | | | 4 | | |

STD. NO. SP1

| | |
|-----------------------|----------------------|
| ASSEMBLED BY : | DATE : |
| CHECKED BY : | DATE : |
| DRAWN BY : ELR 5/92 | REV. 7/10/01 LES/RDR |
| CHECKED BY : GRP 6/92 | REV. 5/7/03 RWW/JTE |
| | REV. 5/1/06 TLG/GM |